

# National Ecological Observatory Network

## Sensors

T. Cilke / Instruments & Integration

H. Loescher / FIU & MDP

H. Powell / Aquatic & STREON

L. Newton / CAL/VAL

# Outline

- **NEON System Component**
- **Scope & Deliverables**
- **Realization Process**
- **Development Status**
- **Organization**
- **WBS Overview - Budget & Schedule**
- **Risks**
- **Summary**

# NEON System Architecture

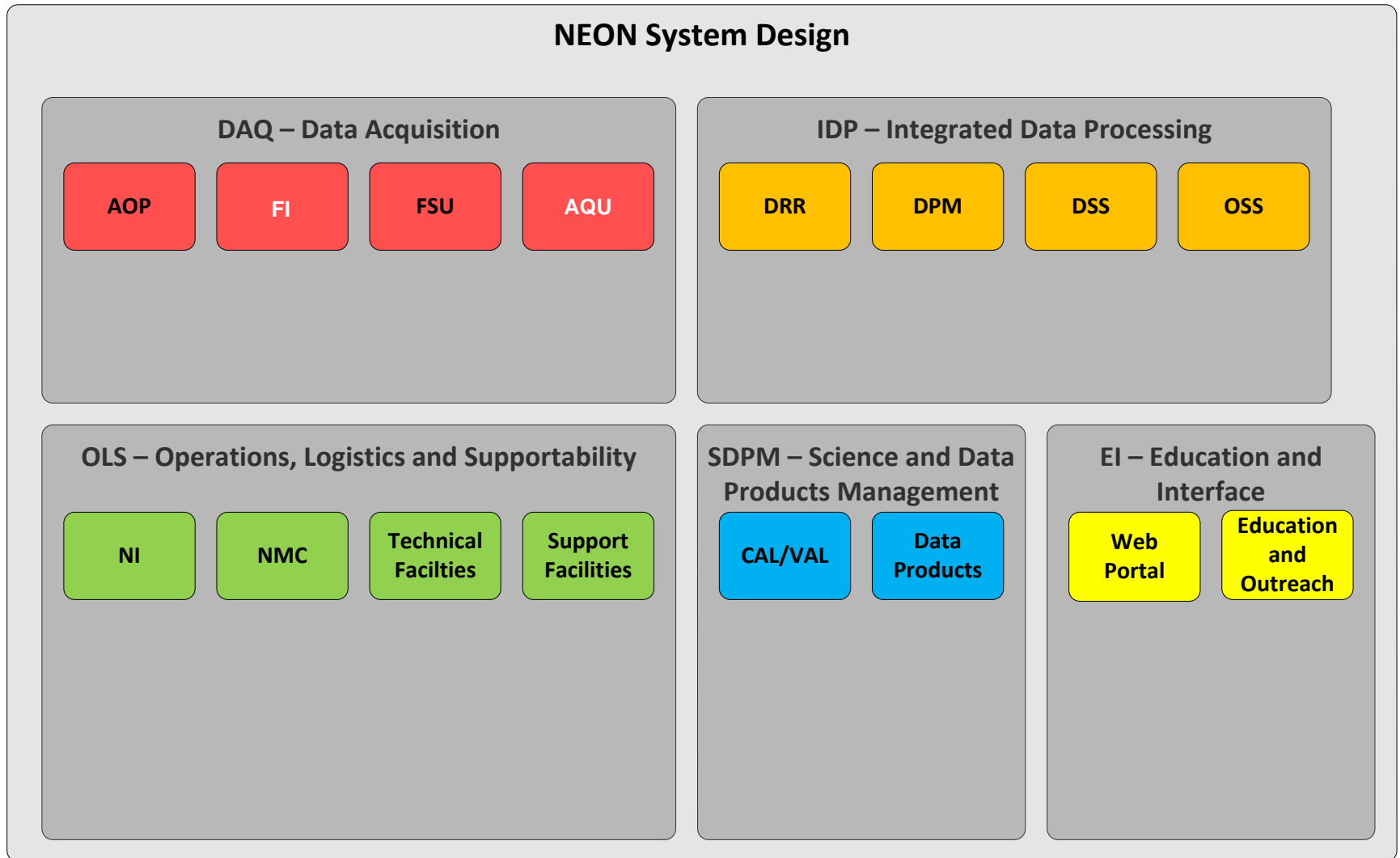

# NEON Sensor Systems Areas

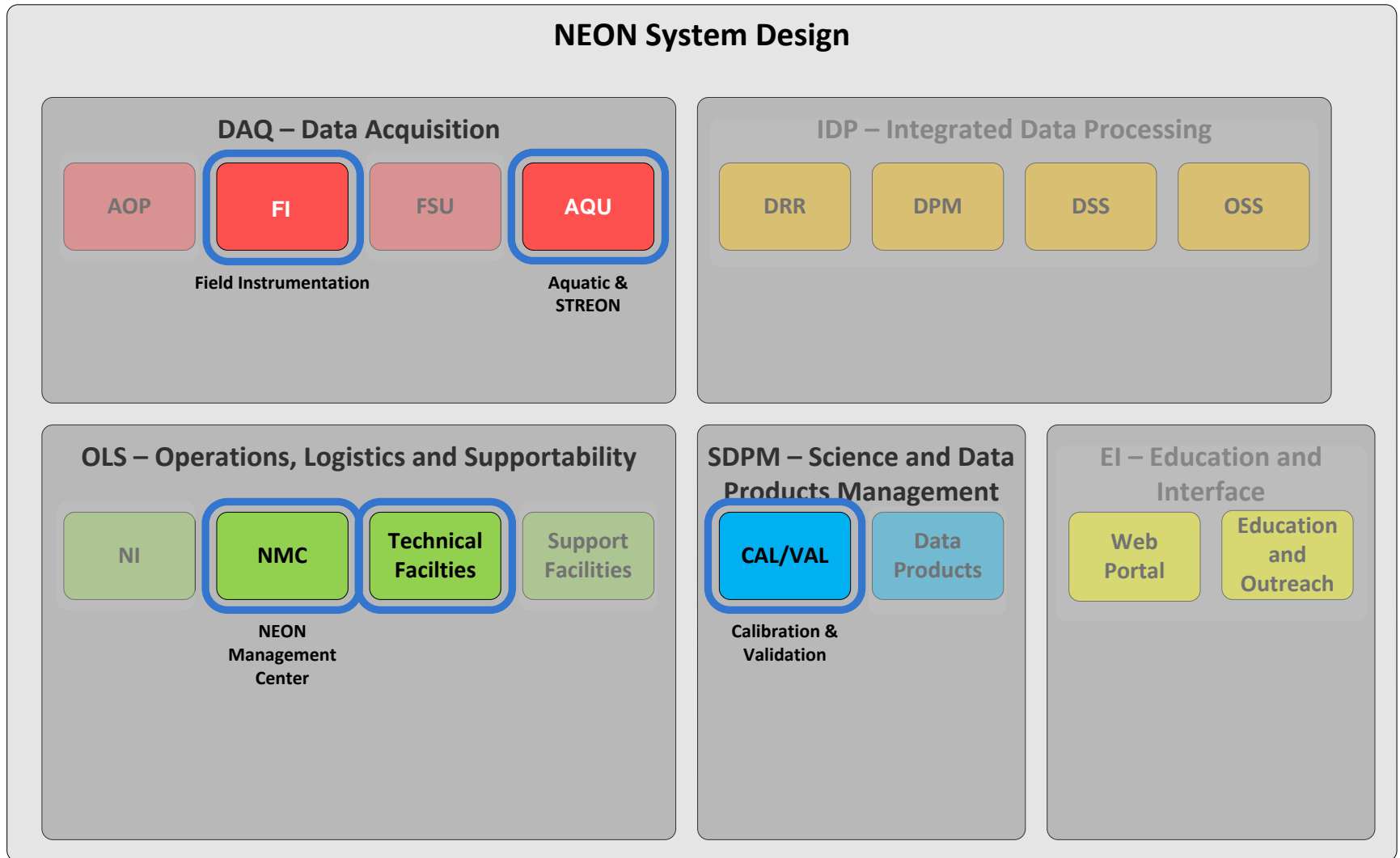

# NEON Sensor Systems Components

## NEON System Design

### DAQ – Data Acquisition

AOP

**FI**

FSU

**AQU**

1. FIU
2. MDP

1. Streams
2. Ponds
3. STREON

### IDP – Integrated Data Processing

DRR

DPM

DSS

OSS

### OLS – Operations, Logistics and Supportability

NI

**NMC**

**Technical  
Facilities**

Support  
Facilities

- |   |   |
|---|---|
| <ol style="list-style-type: none"> <li>1. Control Center</li> </ol> | <ol style="list-style-type: none"> <li>1. Assembly Fabrication Lab</li> <li>2. Maintenance and Repair Lab</li> <li>3. Advanced Development Lab</li> <li>4. FIU Proto, Eval &amp; Training Lab</li> <li>5. AQU Proto, Eval &amp; Training Lab</li> <li>6. CAL/VAL Sensor Calibration Lab</li> <li>7. CAL/VAL Sample Audit Lab</li> <li>8. CAL/VAL Sensor Field Cal Lab</li> <li>9. CAL/VAL Field Eval Lab</li> </ol> |
|---|---|

### SDPM – Science and Data Products Management

**CAL/VAL**

Data  
Products

1. Level 0 Data Quality

### EI – Education and Interface

Web  
Portal

Education  
and  
Outreach

# Objectives

- Provide an enabling field based data acquisition infrastructure geared towards supporting research into the understanding and forecasting of climate change, land use change and invasive species on continental-scale ecology.
- Ensure high quality, reliable and consistent measurement data products using uniform methods to serve as context for long term and continental wide research and education.
- Generate temporally and spatially uniformly generated basis set of ecological measurements to serve as the initial and foundational data product suites.
- Provide a research platform for future investigator-initiated sensors, observations and experiments.

# NEON Sensor Systems Realization

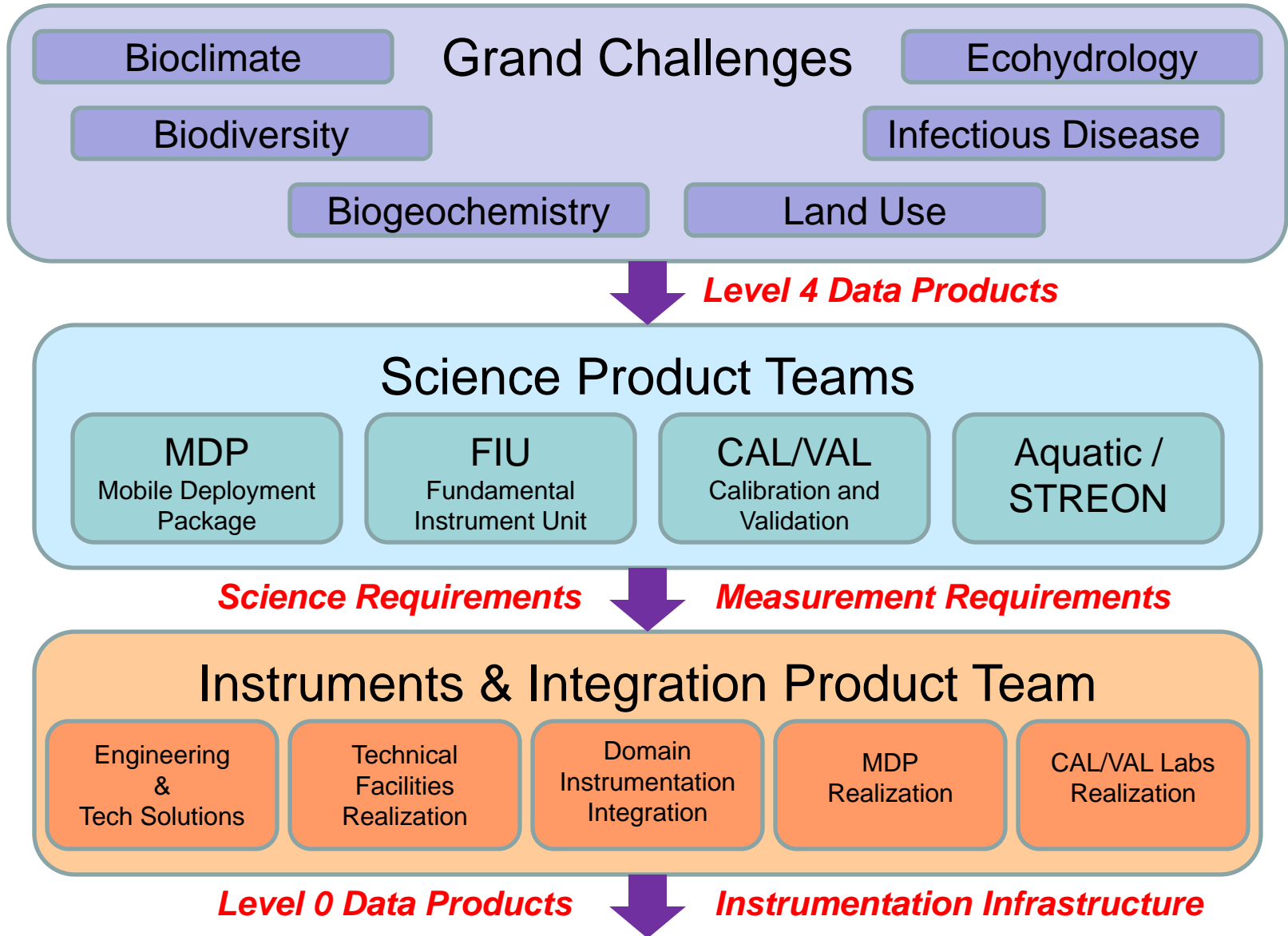

# Roles and Responsibilities

## Science Product Teams

(AQU/STREON, FIU, MDP, CAL/VAL)

Science & measurement requirements.  
Data product development.  
Sensor evaluation and selection.  
Instrumentation design oversight.  
Domain characterization.  
Instrumentation commissioning.  
Data product QA/QC.  
Domain commissioning.

## I&I Tech Solution Team

Instrumentation development.  
Technology development and evaluation.  
Ops, fabrication, test, training & maintenance documentation.

## I&I Domain Integration Team

Deployment, evaluation and test of all FIU, Aquatic & STREON field instrumentation.  
  
Development and deployment of MDP

## I&I Support Facilities Team

1. Control center & monitoring
2. Assembly fabrication
3. Maintenance and repair
4. Sensor calibration and validation
5. Sample audit preparation
6. Domain evaluation and calibration
7. FIU & Aquatic field eval & training

# Scope & Deliverables

- **Science Product Teams Deliverables**
  - Pre construction location characterization
  - Measurement suite definition and sensors (~ 50 different types)
  - Data product development
  - Data product QA/QC
  - Assembly and domain measurement commissioning
- **Instruments and Integration Product Team Deliverables**
  - Domain data acquisition (~15000 sensors & ~2400 DAS)
  - Remote network (Ethernet & wireless) and power (UPS & Solar)
  - Field tools and test equipment
  - Support Facilities (Control Center, Assembly, Repair Labs)
  - Advanced development and training
  - Domain instrumentation integration
- **CAL/VAL Product Team Deliverables**
  - Sensor CAL, Sensor Field CAL, Sample Audit Labs and Field Eval and CAL system

# Sensor Systems Components

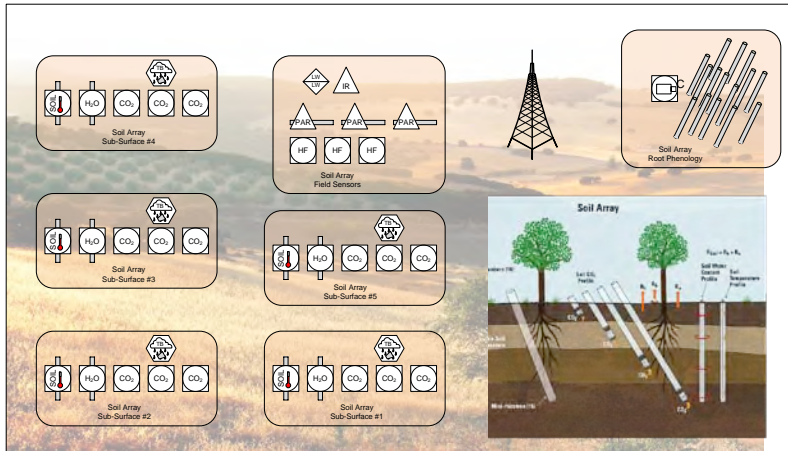

FIU Field and Soil Arrays

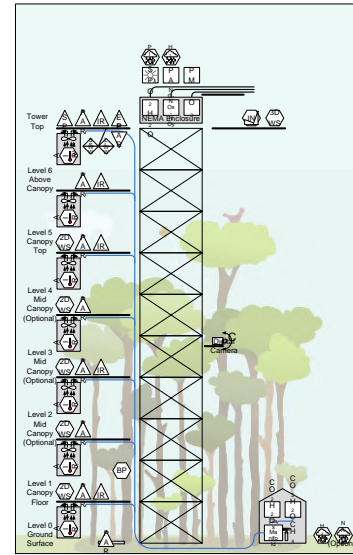

FIU Tower

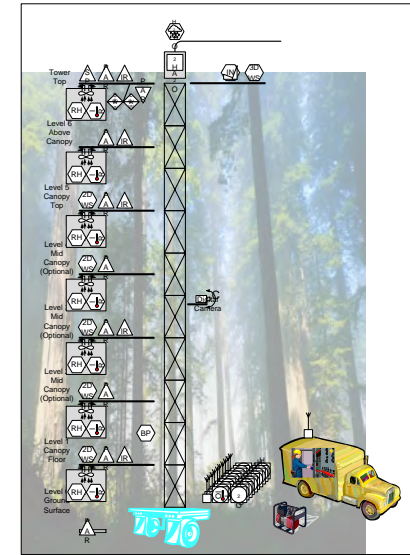

Mobile Deployment Platform

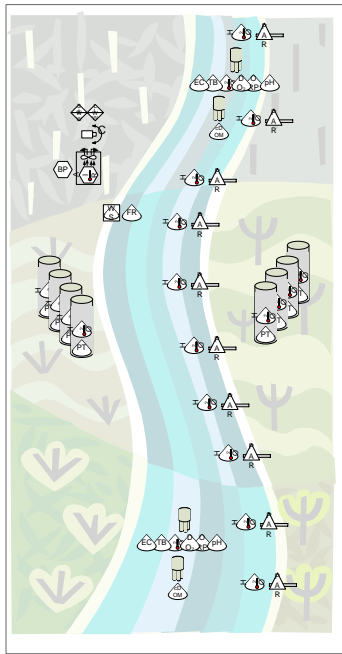

Aquatic Stream

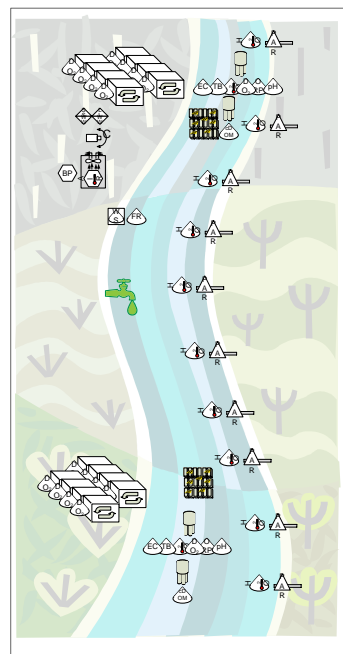

Aquatic Stream

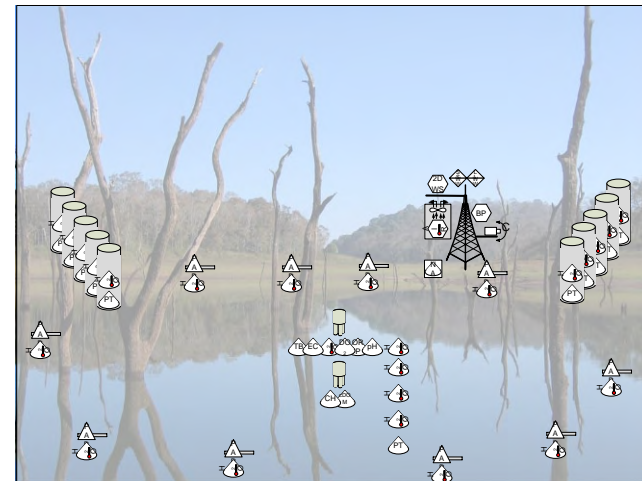

Aquatic Pond

# Realization Plan Overview

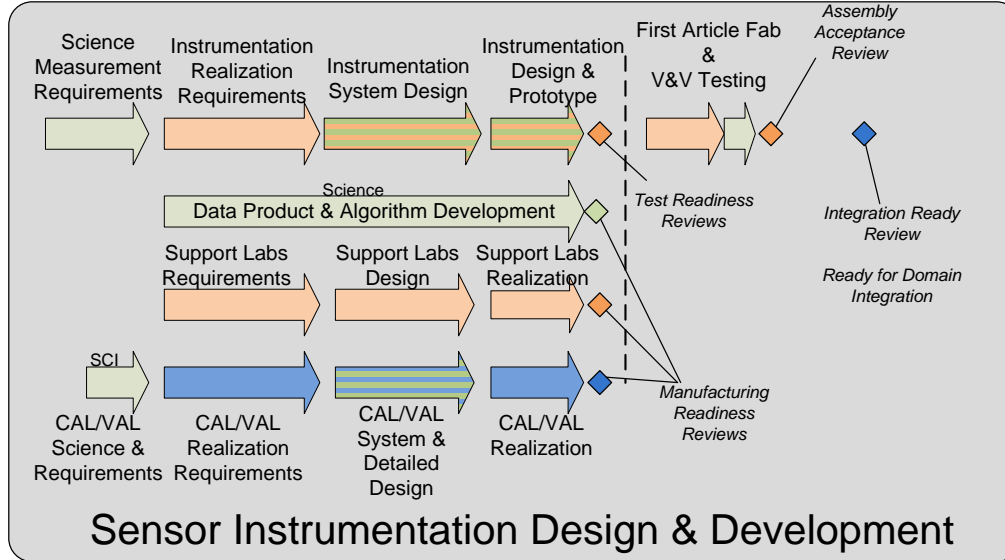

**Realization is combined coordinated effort of integrated science, engineering and facilities product teams.**

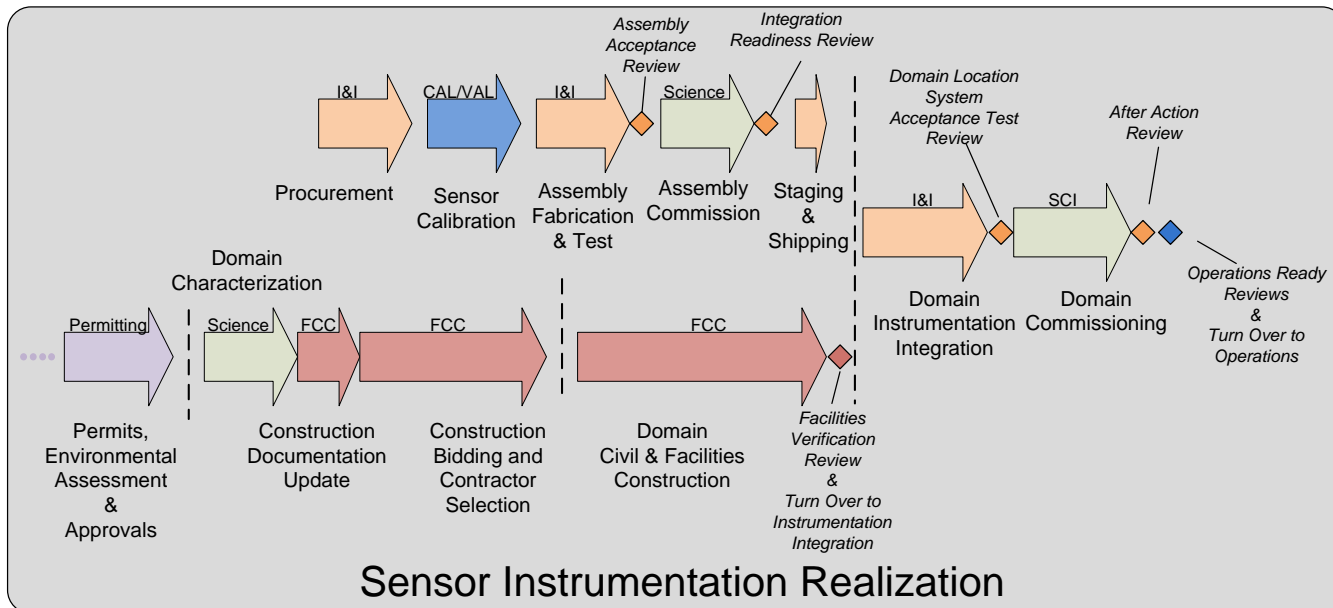

**Design reviews are planned at all key milestones.**

# Development Process

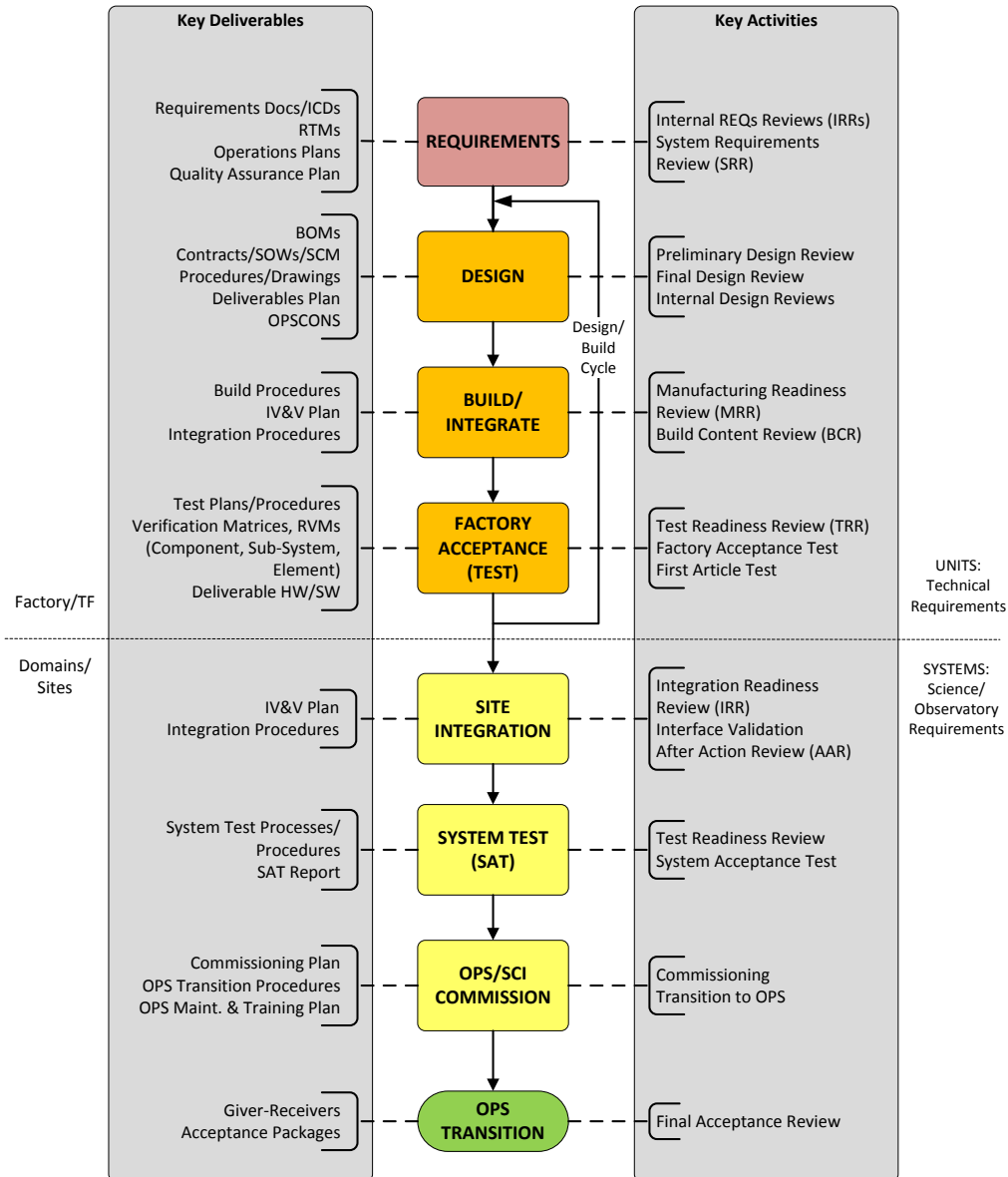

**All development is being performed following a rigorous top down system design process.**

**All designs are reviewed and controlled.**

**Validation and verification testing to be performed to ensure compliance to requirements.**

**Problem tracking, lessons learned and continuous improvement are an integral part of the development.**

# Status Overview

- **Completed characterization plans and started domain characterization process.**
  - Completed wind rose evaluation
- **Established all science data products, measurement requirements and sensor selections.**
- **All Instrumentation assemblies, remote networking and power distribution have been defined.**
  - In process of completing all prototypes, first article acceptance & docs.
  - Materials to build many prototype assemblies have been received.
- **Completed visits to other facilities and with science community experts to review protocols and ensure concurrence with established industry and scientific standards.**
- **Completed design of new FIU tower**
  - Improved safety, lower cost, enhanced capabilities.
- **Completed trade studies and performance evaluations**
- **Completed investigation into contracting out assembly fabrication**
- **Completed on-site visits to domain locations**
- **Completed initial layout of all CAL/VAL and assembly fabrication Labs**
- **Completed CAL/VAL and assembly fabrication process flows**

# Status Overview

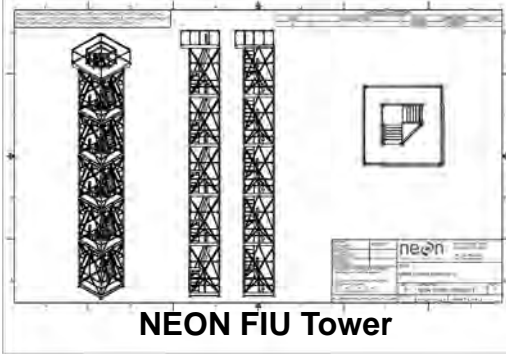

## Location Visits



## Equipment Layout Designs

Equipment	Location	Status
...	...	...

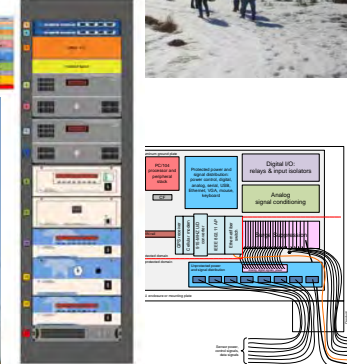

## Data Product Development & QA/QC Process

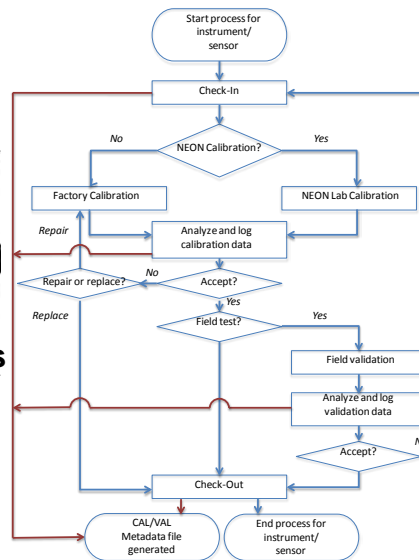

## Calibration Protocols

## Site Characterization

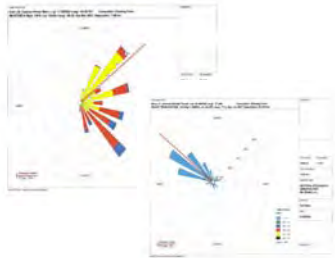

## Assembly Designs

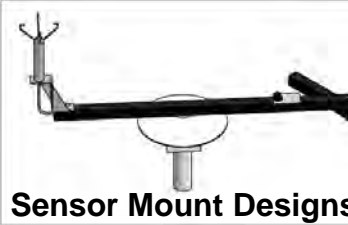

## Prototyping & Evaluation

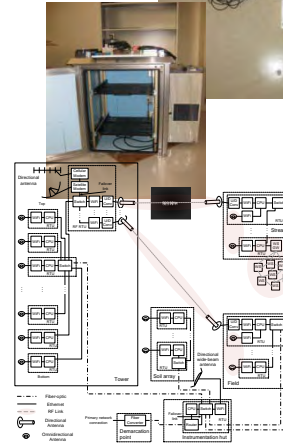

## Network Designs



## Process Development



# Support Facility Labs Overview

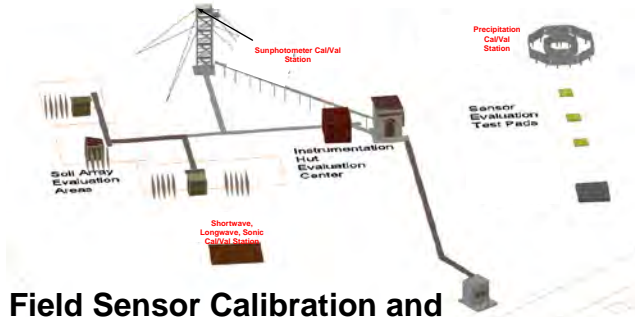

**Field Sensor Calibration and Evaluation Lab (TMTB)**

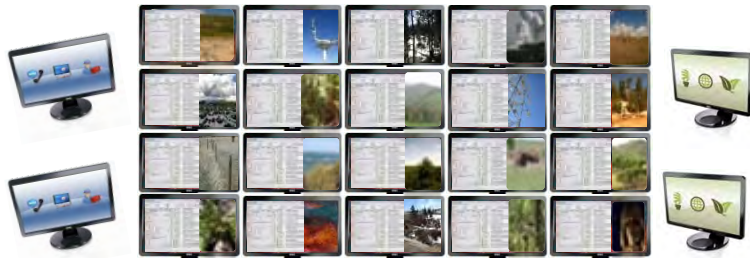

**Control Center**

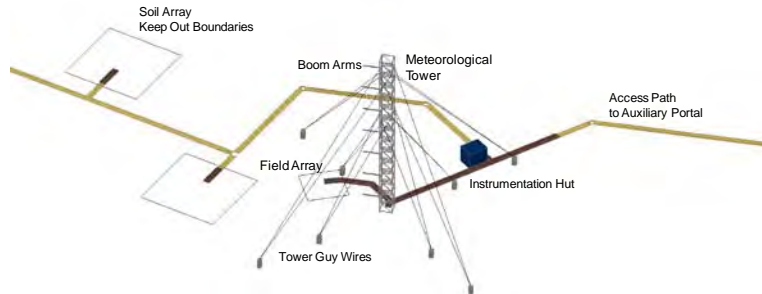

**FIU & AQU – Field Prototype, Evaluation & Training Labs**

**Completed initial lab layouts and selection of all test equipment, tooling and materials.**

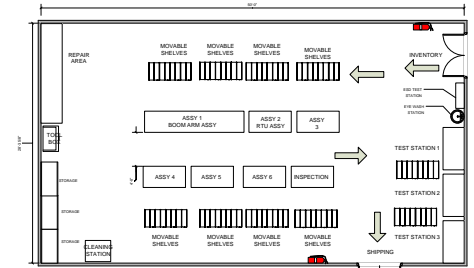

**Assembly Fabrication Lab**

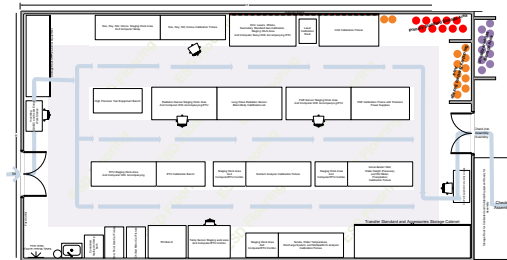

**CAL/VAL Sensor Calibration Lab**

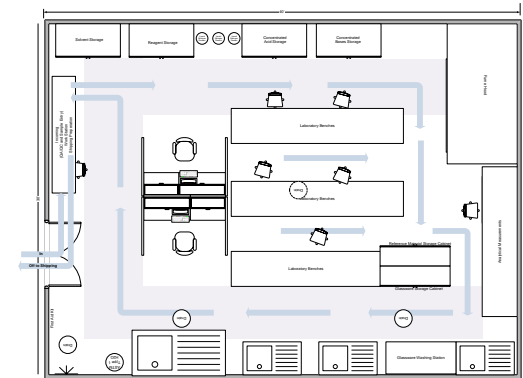

**CAL/VAL Sample Audit Lab**

# Science Product Teams Org Charts

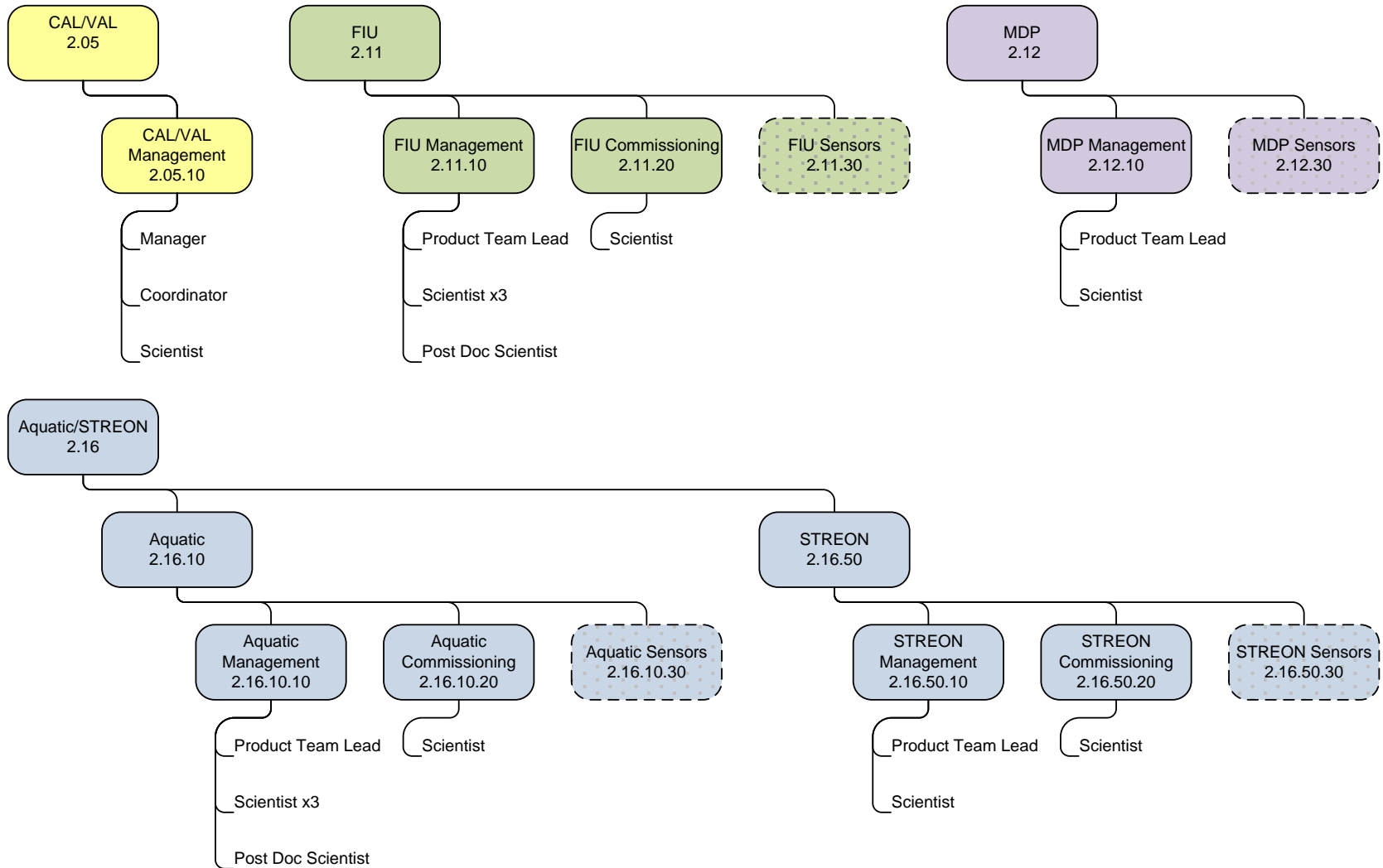

# I&I Product Team Org Chart

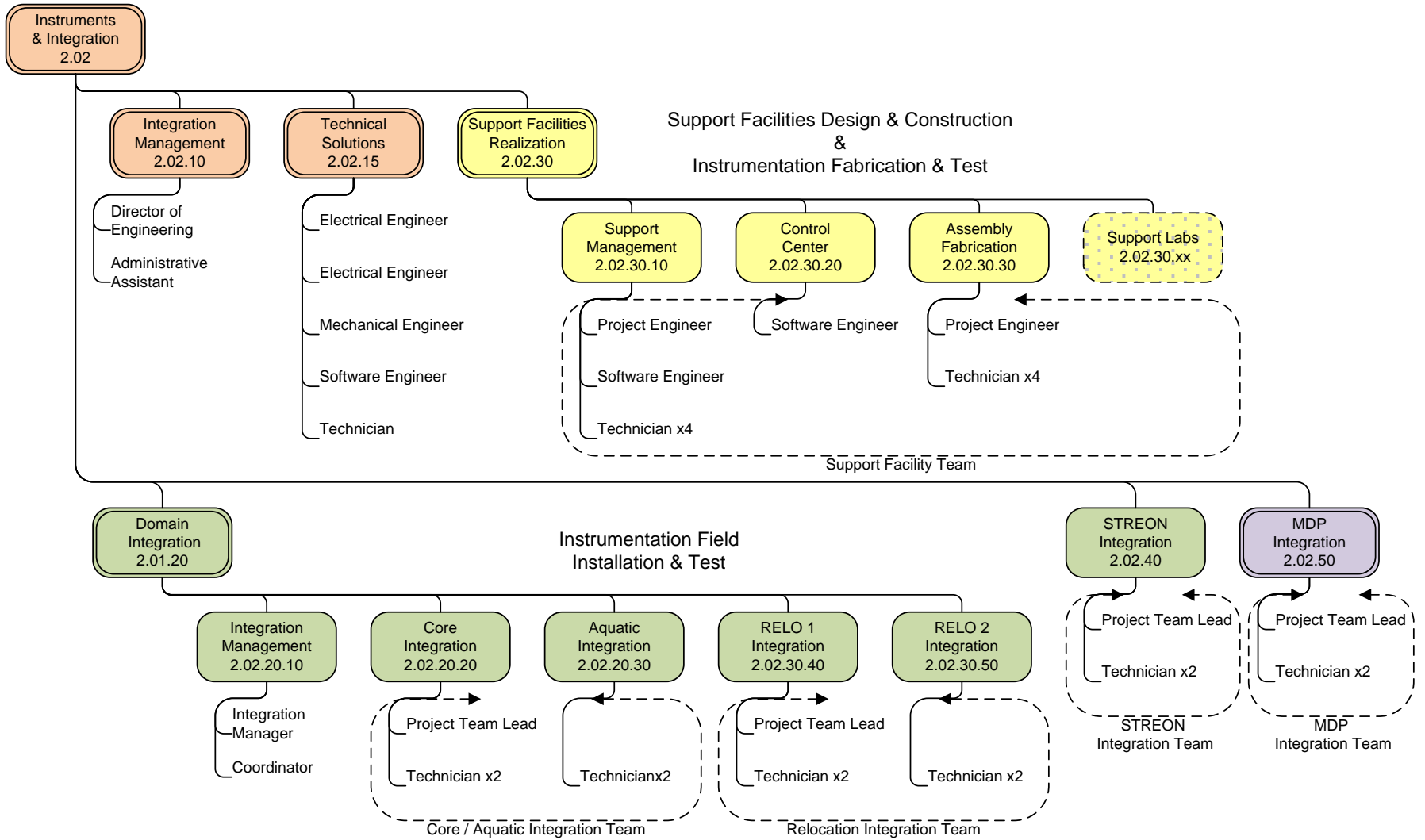

# FTE Spread by FY

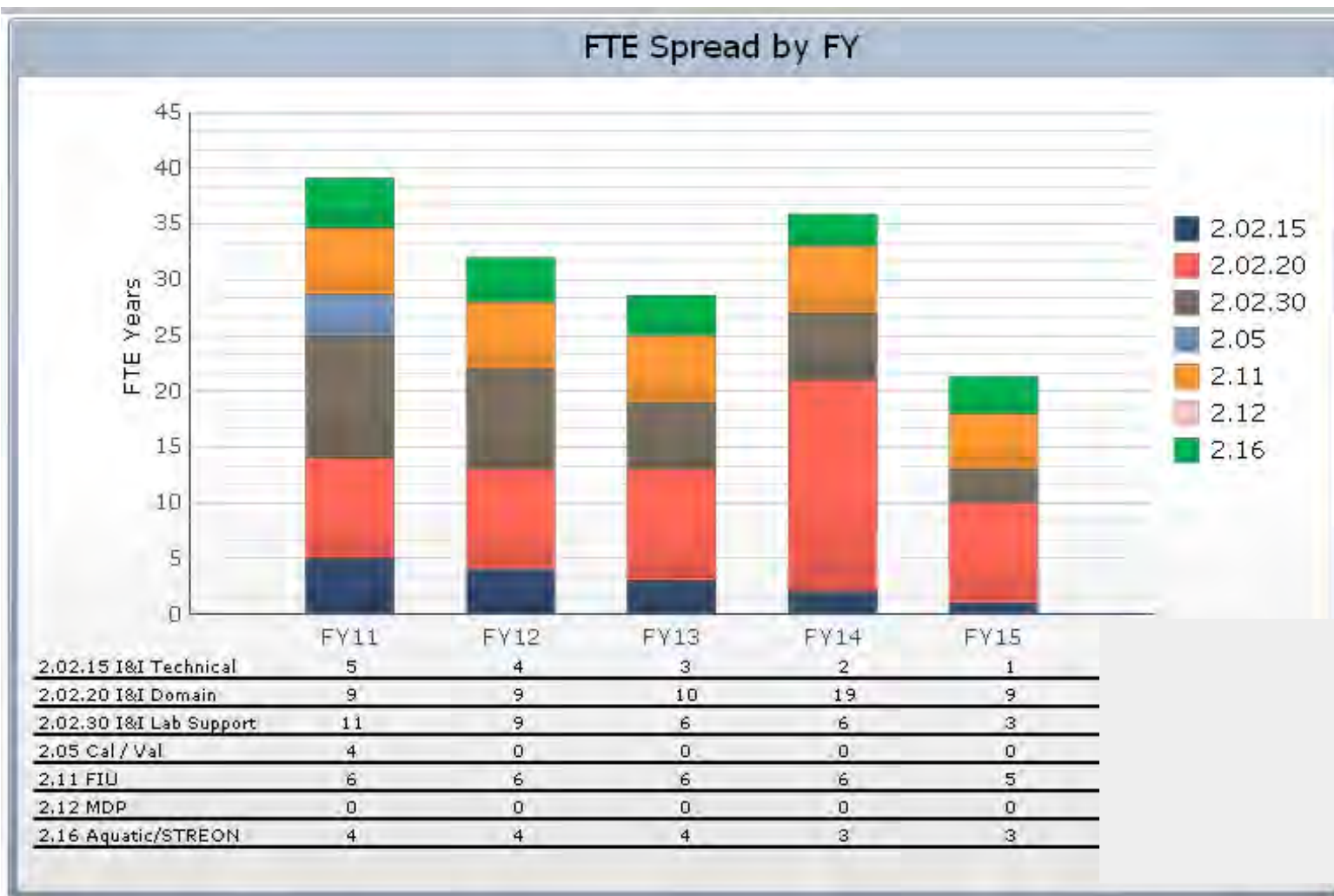

# Sensor Product Team WBS

WBS	Title
<b>2.05</b>	<b>CAL/VAL</b>
2.05.10	CAL/VAL Management
<b>2.11</b>	<b>Fundamental Instrument Unit (FIU)</b>
2.11.10	FIU Management
2.11.20	FIU Characterization & Commissioning
2.11.30	FIU Sensors
<b>2.12</b>	<b>Mobile Deployment Platform (MDP)</b>
2.12.10	MDP Management
2.12.30	MDP Sensors
<b>2.16</b>	<b>Aquatic / STREON</b>
2.16.10	Aquatic
2.16.10.10	Aquatic Management
2.16.10.20	Aquatic Characterization & Commissioning
2.16.10.30	Aquatic Sensors
2.16.50	STREON
2.16.50.10	STREON Management
2.16.50.20	STREON Characterization & Commissioning
2.16.50.30	STREON Sensors
<b>2.02</b>	<b>Instruments &amp; Integration</b>
2.02.10	Integration Management
2.02.15	Technical Solutions
2.02.20	Domain Sensor Integration
2.02.20.10	Domain Sensor Integration Management
2.02.20.20	Core Site Sensor Integration
2.02.20.30	Aquatic Site Sensor Integration
2.02.20.40	Relocatable Site #1 Sensor Integration
2.02.20.50	Relocatable Site #2 Sensor Integration
2.02.30	Lab Support Facilities
2.02.30.10	Lab Support Management
2.02.30.20	Control Center Lab
2.02.30.30	Assembly Fabrication Lab
2.02.30.40	Maintenance & Repair Lab
2.02.30.50	Field Prototype, Evaluation & Training Labs
2.02.30.60	Advanced Development Lab
2.02.30.70	Domain Filed Evaluation Lab
2.02.30.80	CAL/VAL Labs
2.02.40	STREON Sensor Integration
2.02.50	Mobile Deployment Platform (MDP) Integration

# FIU PT Risk Summary

Total Number of Risks					
0.9	1			1	
0.7					
0.5			2	1	
0.3			4		
0.1	1	3	3		
	1	2	3	4	5

Impact

<b>Total Number of Risks</b>	<b>16</b>
<b>Total Occurrence Cost of Risks</b>	<b>\$ 3,174,000</b>

Near-Term Risks					
0.9					
0.7					
0.5					
0.3					
0.1					
	1	2	3	4	5

Impact

Mid-Term Risks					
0.9	1			1	
0.7					
0.5			1	1	
0.3			2		
0.1	1	3	3		
	1	2	3	4	5

Impact

Far-Term Risks					
0.9					
0.7					
0.5					
0.3					
0.1					
	1	2	3	4	5

Impact

# CAL/VAL PT Risk Summary

		Total Number of Risks				
Probability	0.9					
	0.7					
	0.5					
	0.3				1	1
	0.1				4	1
			1	2	3	4

Total Number of Risks	7
Total Occurrence Cost of Risks	\$ 540,000

		Near-Term Risks				
Probability	0.9					
	0.7					
	0.5					
	0.3					
	0.1					
			1	2	3	4

Impact

		Mid-Term Risks				
Probability	0.9					
	0.7					
	0.5					
	0.3				1	1
	0.1				4	1
			1	2	3	4

Impact

		Far-Term Risks				
Probability	0.9					
	0.7					
	0.5					
	0.3					
	0.1					
			1	2	3	4

Impact

# AQU PT Risk Summary

Total Number of Risks					
0.9					
0.7		1			
0.5			1	1	1
0.3		3	3	2	
0.1	1	1	1		
	1	2	3	4	5

Impact

Total Number of Risks	15
Total Occurrence Cost of Risks	\$ 3,100,000

Near-Term Risks					
0.9					
0.7					
0.5					
0.3					
0.1					
	1	2	3	4	5

Impact

Mid-Term Risks					
0.9					
0.7		1			
0.5			1	1	1
0.3		3	3	2	
0.1		1	1		
	1	2	3	4	5

Impact

Far-Term Risks					
0.9					
0.7					
0.5					
0.3					
0.1					
	1	2	3	4	5

Impact

# ENG PT Risk Summary

Total Number of Risks					
0.9				2	
0.7			1		
0.5			2	1	2
0.3		4	7	1	1
0.1	1	3	3	3	2
	1	2	3	4	5

Impact

Total Number of Risks	33
Total Occurrence Cost of Risks	\$ 16,009,000

Near-Term Risks					
0.9					
0.7					
0.5					
0.3					
0.1					
	1	2	3	4	5

Impact

Mid-Term Risks					
0.9				2	
0.7					
0.5			2		2
0.3		4	5		1
0.1	1	3	3	2	2
	1	2	3	4	5

Impact

Far-Term Risks					
0.9					
0.7			1		
0.5					
0.3					
0.1					
	1	2	3	4	5

Impact

# FIU/AQU/ENG/CALVAL PT Risk Register

Risk ID	Risk Title	Description	RRS	Risk Exposure	Occurrence Cost	Program Area	Status
63	All aspects of all designs are not accounted for.	Observatory deliverables include custom mechanical fixtures, cable assemblies and data acquisition components. These are being designed based on requirements, assumptions and information provided by a wide variety of sources. The risk is that until a deliverable is completely designed, first article built, V&V testing completed and field proven, there is the potential some aspect of the design will be missed requiring extensive rework or new designs.  Cost: Potential engineering design \$50k-\$300K, Fab and implementation \$100k-\$500K.	3.6	High	\$ 2,000,000	ENG	Mitigate
115	Supplemental training of technician field staff	insufficient training lead to failure to produce useful FIU data. Currently, production of training materials are in the FIU budget. Mitigation would include supplemental training of field technicians by FIU staff.  Cost: 25k per workshop, 4 workshops during construction	3.6	High	\$ 100,000	FIU	Mitigate
171	Unanticipated problems during instrumentation integration	Each domain location will have unique characteristics and problems that will not become evident until the integration team arrives on site and tries to install the instrumentation. Examples include buried structures, neighboring property owner complaints and dense vegetation. The risk is that a significant change to the location or redesign will need to be made to complete the domain integration.  Cost = 20K * 105 Total Sites = 2.1M	3.6	High	\$ 2,100,000	ENG	Assess
71	Flash Flooding	High flow volumes due to storm damage to instrumentation.  Cost: \$20k per occurrence, covers sensor replacement. Estimating 50 occurrences.	2.5	High	\$ 250,000	ENG	Mitigate
72	Soil Arrays	Below ground structures compromising our ability to measure the in situ environment, particularly in hill slopes and permafrost. Drilling cost impact. Relocation of soil array.  Cost: \$15K per structure * 50% probability * 300 total sites = 2.25M. All estimated cost is for construction fees.	2.5	High	\$ 2,250,000	ENG	Mitigate
151	Sufficient and experienced temporary labor	Sufficient personnel (temporary labor) with specific qualifications is required at each site to complete Aquatic/STREON tasks. In particular, fish sampling and rating curve development/verification requires prior experience. If personnel are not available in some domains, Aquatic/STREON will either have to pay travel costs for personnel to travel between domains or may have to pay a higher rate (e.g. contract a higher skilled person at a higher rate who is available).	2.5	High	\$ 200,000	AQU	Monitor
169	STREON Equipment Not COTS	The STREON experiment relies on equipment that was developed by independent researchers but is not commercially available. The risk is that NEON is relying on a experimental design that may need additional upgrades for use in the NEON observatory.  Cost Estimate: 20K*10 Sites = 200K	2.1	Medium	\$ 200,000	ENG	Monitor

# FIU/AQU/ENG/CALVALPT Risk Register

Risk ID	Risk Title	Description	RRS	Risk Exposure	Occurrence Cost	Program Area	Status
58	New designs may have negative impact on science measurement	"Some instrumentation deliverables are not off the shelf and have to be designed. The impacts of these new designs have an unknown or untested impact to the phenomenology being measured. The risk is that some components may have to be redesigned."  Cost: This is a risk that may require outside consultation from a multiple of firms. \$100k will be used to cover such expenses.	2	Medium	\$ 100,000	ENG	Mitigate
133	Inability to Retain and Recruit Skilled FIU Staff	Recruitment and keeping of key (appropriately trained and educated) FIU Science staff during design, construction, commissioning, and transfer over to Science operations.  Cost: 150k base for construction and 40 k y-1 in OPS for 10 y	2	Medium	\$ 550,000	FIU	Monitor
138	Domain Lab Operations	The domain lab must be constructed, staffed, and stocked with equipment and consumables in order for Aquatic/STREON to operate a site. A space to store equipment and process samples is required for Aquatic/STREON site characterization, but this space can be rented.	2	Medium	\$ 300,000	AQU	Monitor
170	COTS Mobile tower may not have adequate performance	NEON is proposing a COTS mobile tower configuration. The risk is that it will not be possible to fully evaluate the performance of the configuration until a prototype is built and tested.  The cost to evaluate a mobile tower is on the order of \$200K to \$250K for the tower and labor to perform the evaluation.	2	Medium	\$ 200,000	ENG	Mitigate
60	QA/PA of critical components	Vendor fails to deliver parts or equipment that meet quality or other requirements. The risk is a delay in fabrication or repair of assemblies.  Cost: \$25k for testing of new product.	1.5	Medium	\$ 25,000	ENG	Mitigate
89	Black-Body Source	Design and construction of black-body radiation source that do not meet quality standards.  Cost: Cost to contract to (re)design and build 1 black-body calibration devices equal to in-house cost estimate.	1.5	Medium	\$ 190,000	CAL/VAL	Monitor
140	CI is ready to accept data from site characterization	If CI is not able to accept data from site characterization, there may be a cost increase to process and QC data by HQ staff	1.5	Medium	\$ 300,000	AQU	Monitor

# Summary

- **Integrated science and engineering development effort.**
- **Near term future work**
  - Completing domain characterization, documentation, prototyping, realization of support facilities, performing first article validation & verification testing, and operation procedures.
- **Low development risk**
  - High use of COTS, commercially available technologies and standard measurement protocols & techniques.
  - High quality design, configuration control and manufacturing.
- **Providing an enabling capability to the science community**
  - Consistent methods.
  - High data quality control.
  - High reliability.
  - Continental wide standardized measurement suites.
  - Standard easy to integrate new science interfaces.



**NATIONAL ECOLOGICAL OBSERVATORY NETWORK**

The National Ecological Observatory Network is a project sponsored by the National Science Foundation and managed under cooperative agreement by NEON Inc.